

COMPANY PROFILE

LEVIN POWER ENGINEERING

YOUR BEST POWER SOLUTIONS PARTNER

We provide supply, installation and maintenance service of Electrical Substation, Switchgear, BBT, PFI, Electrical Control Panel, Diesel Generator and Related Electrical equipments.



LEVIN POWER ENGINEERING

Corporate Address:

House # 24/8 (3rd Floor), Mirpur, Pallabi,
Begum Rokeya Saroni, Mirpur-10, Dhaka-1216

Factory Address:

Eastern Housing Dhaka, Mirpur



+88 01723889719



info@levinpowerbd.com



www.levinpowerbd.com

Content List



01. Introduction
02. Scope of works
03. About design
04. About Factory
05. Tools
06. Customer Reference

Scope of Works



01. SUBSTATION

02. BBT(BUSBAR TRUKING SYSTEM)

03. GENERATOR

04. ALL KIND OF PANELS

05. REGULAR CABLE TRAY

06. WIREMESH TRAY

07. ELECTRO-MECHANICAL
INSTALLATION

INTRODUCTION TO LEVIN POWER ENGINEERING



ABOUT US LEVIN POWER ENGINEERING

LEVIN POWER ENGINEERING is a engineering function based company in Bangladesh which was established in the year 2022. We are committed to the best quality & services in committed time and customer's satisfaction is our best priority.

The company geared to offer quality Transformer, switchboards, BBT(Busbar Trunking System) at competitive prices and comprise a CAD department with experienced staff capable of handling the most complex specifications. Systems and methods are adopted on a continuous basis to improve the overall quality of the product.

We are working with total electro-mechanical solution as per BNBC & NFPA guideline.

We are manufacturing Transformer, HT/LT switchgear, Change over switch, AVR, PFI plant etc. We have a experienced installation team for supply, installation, commissioning & complete electrical substation of different capacity in our own factory.

In addition, this company represents reputed European brand Diesel Generator, Internal electrical works for industry and building, Fire detection and Hydrant system, compressor, boiler, Chiller, Building Management System (BMS), Solar Power

AFTER SALES AND SERVICE

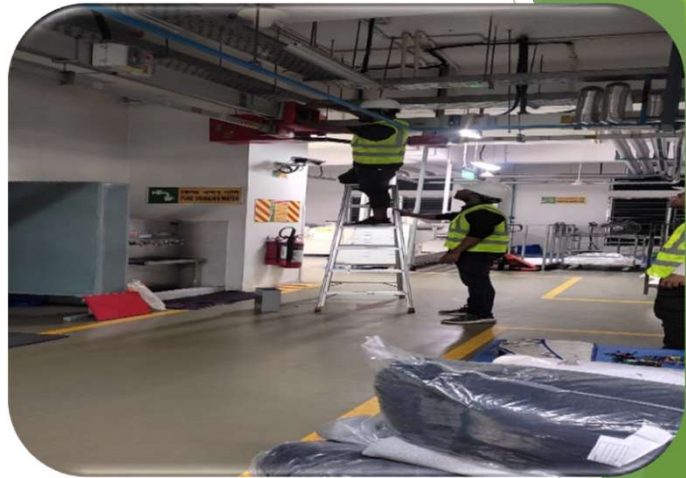

To maintain and provide satisfactory after sales service to the honorable customers, we have established a separate service division under LEVIN POWER ENGINEERING. This service division is staffed with a strong maintenance team comprising of required manpower having graduate & diploma Engineer, skilled & semi-skilled personnel.

“TESTING TOOLS





MESSAGE FROM MANAGEMENT

We procure our service products from the most trusted and renowned supplier. We also manufactured transformer and substation equipment's in our own factory using top grade raw material. We have been carrying our business under specific principles like providing optimum quality products, timely delivery of consignments with customer satisfaction and competitive price. In addition to this, with the support of our team, we are able to gain a trustworthy relationship with our patrons in a short span of time.

Through our upright management, "Levin Power Engineering" makes continuous efforts to achieve the best customer satisfaction.

Thank You for your support.

SUBSTATION AUTOMATION

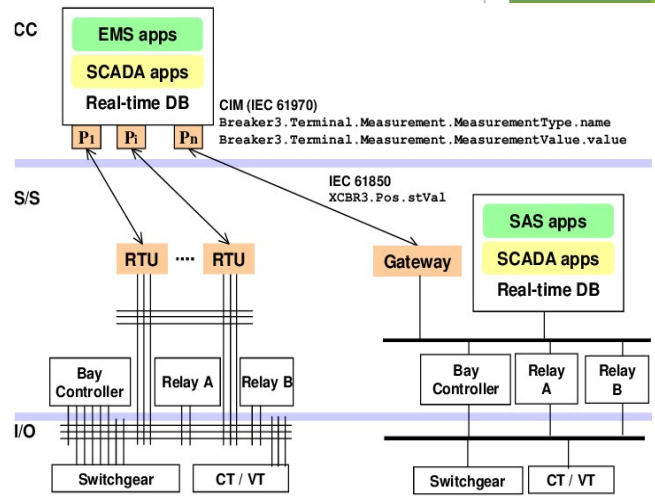

LEVIN POWER ENGINEERING works with both IEC-61850 and MODBUS based substation monitoring and control system. The service under this section includes:

Designing overall conceptual diagram of SAS Making I/O list
Making and Testing Connection Diagram Establishing
Communication amongst Devices and Test Them



RISING POWER ENGINEERING Vision and Mission

VISION

To be the leader in intelligent solutions for electrical energy sectors through excellence in customer service and smart innovation.

MISSION

To providing best possible engineering service experience to our clients with the while maintaining our core values of Quality, Safety, Integrity, Excellence, Relationship and Innovation.

Our Core Values

We believe in the following core values in serving our clients & partners.

QUALITY

We ensure to our clients for best quality of our services.

SAFETY

Achieve Health, Safety and Environment first at all times.

INTEGRITY

Honesty, respect and fairness are the principles of our company and people.

EXCELLENCE

Our objective is to deliver only the very best and set high standards of performance.

RELATIONSHIP

Our commitment to our partners and clients is to create long term relationships.

INNOVATION

Constantly we search new and creative technology to achieve excellence in all areas.

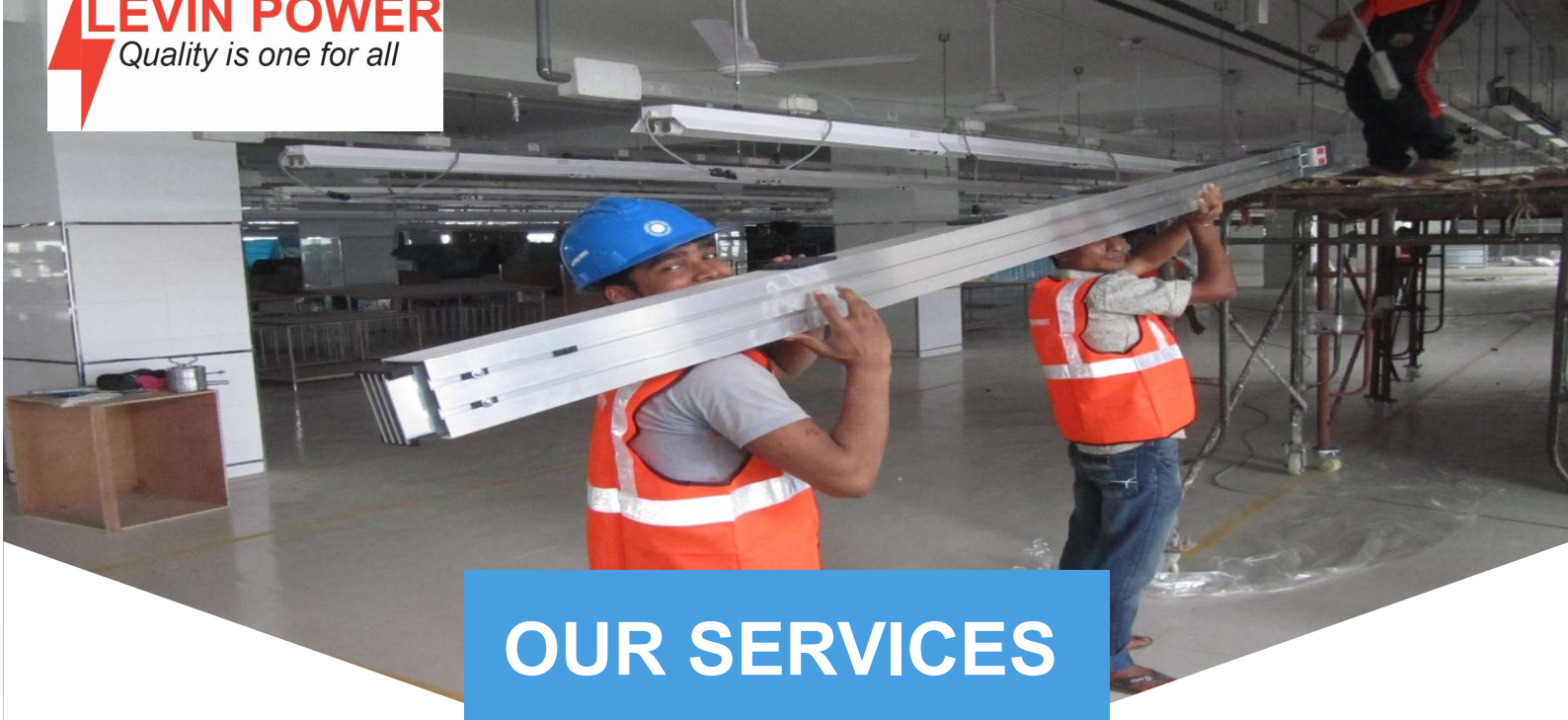

OUR SERVICES

Levin Power Engineering is a field of Power Sector in Bangladesh which was established with a view to provide economic and reliable power supply equipment for the industrial and real estate sectors.



ELECTRICAL SUBSTATION

We provide supply, installation and maintenance service of Substation (100kVA to 4000kVA)



DISTRIBUTION BOARD

We provide complete AC/DC DB solution as your need.



BUSBAR TRUNKING SYSTEM (BBT)

Supply & installation of BBT in industrial, commercial, and service buildings.



DIESEL GENERATOR

Diesel Generator Sale, Spare Parts Supply and Services.



CABLE TRAY

Supply and installation Overhead & Underground Cable Tray, Cable laying and Termination works.



PFI PANEL & PLANT

Supply, Design, Testing and Commissioning PFI PANEL & PLANT



INDUSTRIAL AUTOMATION SYSTEM

We build smart machines for enable smart manufacturing in your industry.



LIGHTNING PROTECTION SYSTEM (LPS)

Supply and lightning protection system (LPS) both industrial and commercial building.



ELECTROMECHANICAL TURNKEY INSTALLER

Electromechanical Turnkey base project in industrial, commercial and service buildings.



BUILDING MANAGEMENT SYSTEM (BMS)

Our Building Management System (BMS) uses software and hardware to control and monitor the building' equipments such as electric power, lighting, HVAC, fire alarm, lifts, CCTV, Networking access etc.

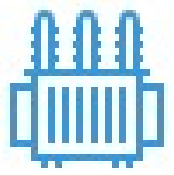

ELECTRICAL SUBSTATION

We provide design, supply, installation and maintenance service of Electrical Substation (100kVA to 4000kVA)



We provide a complete range of distribution and power transformers to grant the reliability, durability and efficiency required in factories, utilities, industries, commercial buildings etc. After sales, we provide complete customer support, including supply and replacement parts.

We offer ready stock of complete HT / LT Substation (up to 33kV) material like - Insulators, LA, Isolators, LBS, Indoor / Outdoor VCB, VCB Panels, CT/ PT, Earthing, GI strips etc.

Our Factory:

Eastern Housing,

Plot No. 1016, B...



BUSBAR TRUNKING SYSTEM (BBT)

Supply and Installation of BBT in industrial, commercial, and service buildings.
Design of BBT as per layout plan



Our Style is modern design and easy installation products so everything is designed to be good looking with minimum fault and loss.

Our BBT partner is **C&S electric**(A
Siemens Organization)





DIESEL GENERATOR

Diesel Generator Sale, Spare Parts Supply and Services.

We provide a large range of diesel generator sets from 9KVA to 2250KVA for residential, hospital and industrial use. We deal with the world famous diesel generator brand.

Diesel Generator from UK



Capacity: 9KVA to 2250KVA

The CPS branding of 'MADE IN THE UK'
Worldwide leader in UK manufactured Diesel generators

Our diesel generator partner is **CPS**





CABLE TRAY

Supply and installation Overhead & Underground Cable Tray, Cable laying and Termination works.

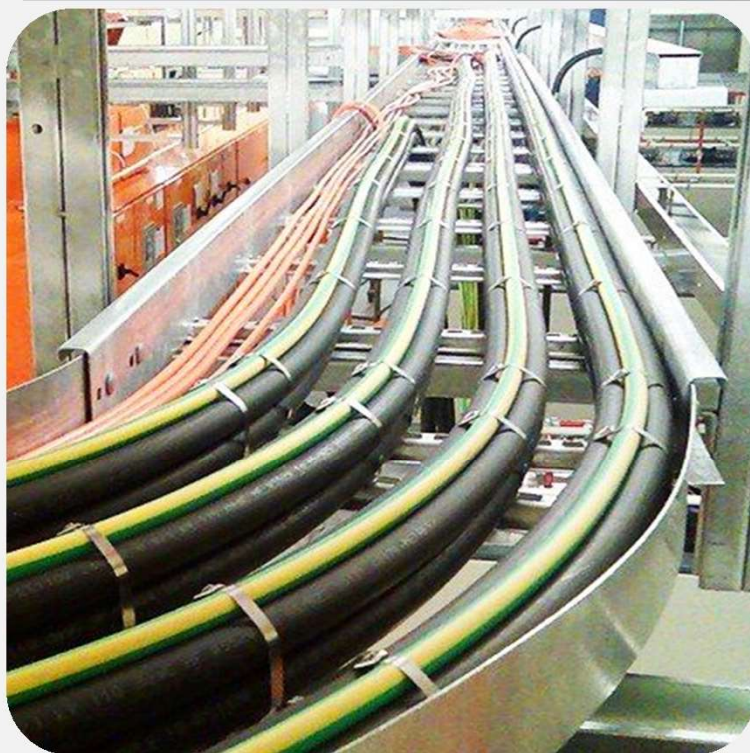
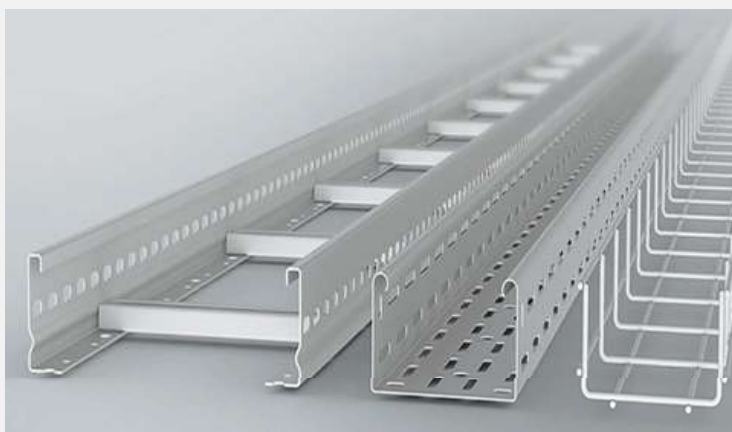

We are manufacturing and Exporting of an exceptional quality of Cable Tray. We using top grade material under the supervision of quality controllers. These cable tray characteristics is easy usability, lightweight, corrosion resistance and high strength.

Material	: GP/MS/SS
Tray Type	: Perforated Cable Tray/ Wire mesh
Cable Tray Coating	: Pre-Galvanized/ Hot Heap Galvanized
Size	: 50mm-900mm
Usage/Application	: Industrial



DISTRIBUTION BOARD & CONTROL PANEL

Rising Power undertakes turnkey medium/low voltage system by providing latest technology to our customers. Any industries/factories, high rise commercial and apartment buildings have been our main working sectors.

Quality is one for all



Usage/Application	: Industrial, Commercial building
Dimension	: Depends on requirement
Material	: Mild Steel
Surface Treatment	: Paint Coated

Our Capabilities:

- Supply and installation electrical substation control panel up to 33kV.
- Design, supply and installation AC/DC distribution switchboard.
- Design, supply and installation PFI Panel.
- Design, supply and installation changeover switchboard.
- Supply and installation star/delta motor control system.

Strengths Of LEVIN POWER ENGINEERING

- ❑ One stop service for all kinds of Electrical Power Engineering.
- ❑ Skilled graduate and diploma engineers, technicians and availability of tools, machinery and parts being our main strength.
- ❑ After sales, provide technical and product support directly and maintain customer satisfaction.
- ❑ LEVIN POWER committed to customer satisfaction through on time completion of services at competitive price.
- ❑ Continuous up gradation of product quality & service through practicing state of the art technology.

QUALITY ASSURANCE

- ❑ We follow best quality control to ensure that our products and services comply with national as well as international standards.
- ❑ We procure best quality of the raw materials from reliable supplier for our products and services.
- ❑ Our quality assurance committed to the efficient and reliable delivery of quality across the sectors we serve.
- ❑ Never compromise quality of our works and products.
- ❑ Our expert quality control management keeps a close monitor in all the stages of our works to ensure zero defect.

We realized that customer satisfaction is the key to success in any business.

VALUED CUSTOMERS



Contact Us:

Head Office:

House:3,(3rd Floor), Road: 36, Block: TA,
Mirpur-12, Dhaka-1216

Factory Address:

Eastern Housing, Mirpur,
Dhaka-1216, Bangladesh

Mobile: +88-01723 889719

Email: info@levingpowerbd.com

www.levinpowerbd.com